

Primary Containment for Biohazards:

Selection, Installation and Use of Biological Safety Cabinets

3rd Edition

DEPARTMENT OF HEALTH & HUMAN SERVICES
Centers for Disease Control and Prevention

and

National Institutes of Health

September 2007

EDITORS:

L. Casey Chosewood, MD
Director, Office of Health and Safety
Centers for Disease Control and Prevention
Atlanta, GA 30333

Deborah E. Wilson, DrPH, CBSP
Director, Division of Occupational Health and Safety
Office of Research Services
National Institutes of Health
Bethesda, MD 20892

CONTRIBUTORS:

Centers for Disease Control and Prevention, Office of Health and Safety

Martin Sanders, PhD CBSP
William Howard, MS
Shanna Nesby, DVM
Robin Weyant, PhD
Henry Mathews, PhD
Jonathan Richmond, PhD
Mike Weathers

National Institutes of Health, Division of Occupational Health and Safety

Edward F. Sorensen III
Mark Gibson, CIH
Doris McKinney

OTHER CONTRIBUTORS:

Lee Alderman
Emory University, Atlanta, GA

Richard Green
Georgia Public Health Lab, Decatur, GA

Gregg Schuiling
NSF International, Ann Arbor, MI

Jack Wunder
University of Wisconsin, Madison, WI

Dennis Eagleson
The Baker Company, Sanford, ME

Steven Kridel
Duke University, Durham, NC

William Peters
Nuaire, Plymouth, MN

The editors would like to extend special thanks to David G. Stuart, PhD, The Baker Company, Sanford, ME for his extensive contributions to this work.

TABLE OF CONTENTS

Section I

Introduction	1
--------------------	---

Section II

The High Efficiency Particulate Air (HEPA) Filter and the Development of Biological Containment Devices....	3
HEPA Filters	4

Section III

Biological Safety Cabinets	6
The Class I BSC	6
The Class II BSC	7
The Class III BSC.....	12
Horizontal Laminar Flow “Clean Bench”	13
Vertical Laminar Flow “Clean Bench”	14

Section IV

Laboratory Hazards and Risk Assessment.....	15
Chemicals in BSCs.....	15
Radiological Hazards in the BSC	17
Risk Assessment	17

Section V

BSC Use by the Investigator:	
Work Practices and Procedures	18
Preparing for Work Within a Class II BSC	18
Material Placement Inside the BSC.....	20
Operations Within a Class II BSC.....	21
Laboratory Hazards	21
Decontamination.....	23
Cabinet Surface Disinfection	23
Gas Decontamination	24

Section VI

Facility and Engineering Requirements	25
Secondary Barriers	25
Building Exhaust.....	25
Utility Services	26
Ultraviolet Lamps.....	26
BSC Placement	26
HEPA Filters	28

Section VII

Certification of Biological Safety Cabinets	30
Development of Containment Standards	30
Performance Testing BSCs in the Field.....	32
A. Downflow Velocity and Volume Test	32
B. Inflow Velocity Test.....	32
C. Airflow Smoke Patterns Tests	32
D. HEPA Filter Leak Test	33
E. Cabinet Leak Test	33
F. Electrical Leakage and Ground Circuit Resistance and Polarity Tests	33
G. Lighting Intensity Test	34
H. Vibration Test	34
I. Noise Level Test	34
J. UV Lamp Test	34
References	50

TABLES

Table 1. Selection of a Safety Cabinet Through Risk Assessment	35
Table 2. Comparison of Biosafety Cabinet Characteristics.....	36
Table 3. Performance Tests to be Applied to the Three Classes of Biological Safety Cabinets	37
Table 4. References for Applicable Containment Tests.....	38

FIGURES

Figure 1.	HEPA Filters
Figure 2.	The Class I BSC
Figure 3.	The Class II, Type A BSC
Figure 4.	Thimble Unit
Figure 5A.	The Class II, Type B1 BSC (classic design)
Figure 5B.	The Class I, Type B1 BSC (bench top design)
Figure 6.	The Class II, Type B2 BSC
Figure 7.	The tabletop model of a Class II, Type B3 BSC
Figure 8.	The Class III BSC
Figure 9A.	The horizontal laminar flow “clean bench”
Figure 9B.	The vertical laminar flow “clean bench”
Figure 10. ..	A modified containment cabinet or Class I BSC
Figure 11.	A typical layout for working “clean to dirty”
Figure 12. ..	One method to protect a house vacuum system
Figure 13.	A bag-in-bag-out filter enclosure

Introduction

SECTION I

Introduction

This document presents information on the design, selection, function and use of Biological Safety Cabinets (BSC), which are the primary means of containment developed for working safely with infectious microorganisms. Brief descriptions of the facility and engineering concepts for the conduct of microbiological research are also provided. BSCs are only one part of an overall biosafety program which requires consistent use of good microbiological practices, use of primary containment equipment and proper containment facility design. Detailed descriptions of acceptable work practices, procedures and facilities, described as Biosafety Levels 1 through 4, are presented in the CDC/NIH publication *Biosafety in Microbiological and Biomedical Laboratories (BMBL)*.¹

BSCs are designed to provide personnel, environmental and product protection when appropriate practices and procedures are followed. Three kinds of biological safety cabinets, designated as Class I, II and III, have been developed to meet varying research and clinical needs.

Most BSCs use high efficiency particulate air (HEPA) filters in the exhaust and supply systems. The exception is a Class I BSC which does not have HEPA filtered supply air). These filters and their use in BSCs are briefly described in Section II. Section III presents a general description of the special features of BSCs that provide varying degrees of personnel, environmental, and product protection.

Laboratory hazards and risk assessment are discussed in Section IV. Section V presents with work practices, procedures and practical tips to maximize information regarding the protection afforded by the most commonly used BSCs. Facility and engineering requirements needed for the operation of each type of BSC are presented in Section VI. Section VII reviews requirements for routine annual certification of cabinet operation and integrity.

Introduction

These sections are not meant to be definitive or all encompassing. Rather, an overview is provided to clarify the expectations, functions and performance of these critical primary barriers. This document has been written for the biosafety officer, laboratorian, engineer or manager who desires a better understanding of each type of cabinet, factors considered for the selection of a BSC to meet specific operational needs and the services required to maintain the operational integrity of the cabinet.

Proper maintenance of cabinets used for work at all biosafety levels cannot be over emphasized. BSOs should understand that an active cabinet is a primary safety device. A BSC must be routinely inspected and tested by trained personnel, following strict protocols, to verify that it is working properly. This process is referred to as certification of the cabinet and should be performed annually.

NOTE: A biological safety canbinet has been administratively decommissioned when a written conditional waiver has been granted by the bio-safety officer and this cabinet is not permitted to be used for work with bio-hazardous or other hazardous materials. The cabinet must be posted with conspicuous signs with wording that makes the situation clear.

SECTION II

The High Efficiency Particulate Air (HEPA) Filter and the Development of Biological Containment Devices

From the earliest laboratory-acquired typhoid infections to the hazards posed by bio-terrorism, antibiotic-resistant bacteria and rapidly-mutating viruses, threats to worker safety have stimulated the development and refinement of workstations in which infectious microorganisms could be safely handled. The needs to work with tissue cultures, maintain sterility of cell lines, and minimize cross-contamination have contributed to concerns regarding product integrity.

The use of proper procedures and equipment (as described in BMBL)¹ cannot be overemphasized in providing primary personnel and environmental protection. For example, high-speed blenders designed to reduce aerosol generation, needle-locking syringes, microburners and safety centrifuge cups or sealed rotors are among the engineered devices that protect laboratory workers from biological hazards. The most important piece of containment equipment, however, is the biological safety cabinet in which manipulations of infectious microorganisms are performed.

Background

Early prototype clean air cubicles were designed to protect the materials being manipulated from environmental or worker-generated contamination rather than to protect the worker from the risks associated with the manipulation of potentially hazardous materials. Filtered air was blown across the work surface directly at the worker. Therefore, these cubicles could not be used for handling infectious agents because the worker was in a contaminated air stream.

To protect the worker during manipulations of infectious agents, a small workstation was needed that could be installed in existing laboratories with minimum modification to the room. The earliest designs for primary containment devices were essentially

HEPA Filters and the Development of BSCs

non-ventilated “boxes” built of wood and later of stainless steel, within which simple operations such as weighing materials could be accomplished.²

Early versions of ventilated cabinets did not have adequate or controlled directional air movement and were characterized by mass airflow with widely varying air volumes across openings. The feature of mass airflow into the cabinet was added to draw “contaminated” air away from the laboratory worker. This was the forerunner of the Class I BSC. However, since the air was unfiltered, the cabinet was contaminated with environmental microorganisms and other undesirable particulate matter.

HEPA Filters. Control of airborne particulate materials became possible with the development of filters which would efficiently remove microscopic contaminants from the air. The HEPA filter was developed to create dust-free work environments (e.g., “clean rooms” and “clean benches”) in the 1940’s.²

HEPA filters remove the most penetrating particle size (MPPS) of 0.3 μm with an efficiency of at least 99.97%. Particles both larger and smaller than the MPPS are removed with greater efficiency. Bacteria, spores and viruses are removed from the air by these filters. HEPA filter efficiency and the mechanics of particle collection by these filters have been studied and well documented^{3,4} therefore only a brief description is included here.

The medium of a typical HEPA filter is a single sheet of borosilicate fibers which has been treated with a wet-strength water-repellant binder. The filter medium is pleated to increase the overall surface area inside the filter frame, and the pleats are often divided by corrugated aluminum separators (Figure 1). The separators prevent the pleats from collapsing in the air stream and provide a path for airflow. Alternate designs providing substitutions for the aluminum separators may also be used. The filter is glued into a wood, metal or plastic frame. Careless handling of the filter (e.g., improper storage or dropping) can damage the medium at the glue joint and cause tears or shifting of the filter resulting in leaks in the medium. This is the primary reason why filter integrity must be tested when a BSC

HEPA Filters and the Development of BSCs

is initially installed and each time it is moved or relocated (See Section VII).

Various types of containment and clean air devices incorporate the use of HEPA filters in the exhaust and/or supply air system to remove airborne particulate material. Depending on the configuration of these filters and the direction of the airflow, varying degrees of personnel, environmental and product protection can be achieved.⁵ Section V describes the proper practices and procedures necessary to maximize the protection afforded by the device.

SECTION III

Biological Safety Cabinets

The similarities and differences in protection offered by the various classes of BSCs are reflected in Table 1. Please also refer to Table 2 and Section IV for further considerations pertinent to BSC selection and risk assessment.

The Class I BSC

The Class I BSC provides personnel and environmental protection, but no product protection. It is similar in air movement to a chemical fume hood, but has a HEPA filter in the exhaust system to protect the environment (Figure 2). In the Class I BSC, unfiltered room air is drawn across the work surface. Personnel protection is provided by this inward airflow as long as a minimum velocity of 75 linear feet per minute (lfpm) is maintained⁶ through the front opening. Because product protection is provided by the Class II BSCs, general usage of the Class I BSC has declined. However, in many cases, Class I BSCs are used specifically to enclose equipment (e.g., centrifuges, harvesting equipment or small fermenters), or procedures with potential to generate aerosols (e.g. cage dumping, culture aeration or tissue homogenation).

The classical Class I BSC is hard-ducted (i.e., direct connection) to the building exhaust system, and the building exhaust fan provides the negative pressure necessary to draw room air into the cabinet. Cabinet air is drawn through a HEPA filter as it enters the cabinet exhaust plenum. A second HEPA filter may be installed in the terminal end of the building exhaust prior to the exhaust fan.

Some Class I BSCs are equipped with an integral exhaust fan. The cabinet exhaust fan must be interlocked with the building exhaust fan. In the event that the building exhaust fan fails, the cabinet exhaust fan must turn off so that the building exhaust ducts are not pressurized. If the ducts are pressurized and the HEPA filter has developed a leak, contaminated air could

Biological Safety Cabinets

be discharged into other parts of the building or the environment. Note that a filter should be installed on the cabinet air supply intake. The use of two filters in the cabinet increases the static pressure on the fan.

A panel with openings to allow access for the hands and arms to the work surface can be added to the Class I cabinet. The restricted opening results in increased inward air velocity, increasing worker protection. For added safety, arm-length gloves can be attached to the panel. Makeup air is then drawn through an auxiliary air supply opening (which may contain a filter) and/or around a loose-fitting front panel.

Some Class I models used for animal cage changing are designed to allow recirculation of air into the room after HEPA filtration and may require more frequent filter replacement due to filter loading and odor from organic materials captured on the filter. The re-circulating Class I BSC should be annually certified for sufficient airflow and filter integrity.

The Class II BSC

As biomedical researchers began to use sterile animal tissue and cell culture systems, particularly for the propagation of viruses, cabinets were needed that also provided product protection. In the early 1960s, the “laminar flow” principle evolved. Unidirectional air moving at a fixed velocity along parallel lines was demonstrated to reduce turbulence and aid in the capture and removal of airborne contaminants from the air stream.⁷ Biocontainment technology also incorporated this laminar flow principle with the use of the HEPA filter to provide a particulate-free work environment. This combination of technologies serves to protect the laboratory worker from potentially infectious microorganisms or materials being manipulated⁴ within the cabinet and provides necessary product protection, as well. Class II BSCs are partial barrier systems that rely on the laminar movement of air to provide containment. If the air curtain is disrupted (e.g., movement of materials in and out of a cabinet, rapid or sweeping movement of the arms) the potential for contaminant release into the laboratory work environment is increased as is the risk of product contamination.

Biological Safety Cabinets

The Class II (Types A1, A2, B1 and B2)⁸ BSCs provide personnel, environmental and product protection. Airflow is drawn into the front grille of the cabinet, providing personnel protection. In addition, the downward laminar flow of HEPA-filtered air provides product protection by minimizing the chance of cross-contamination across the work surface of the cabinet. Because cabinet exhaust air is passed through a certified HEPA filter, it is particulate-free (environmental protection), and may be recirculated to the laboratory (Type A1 and A2 BSCs) or discharged from the building via a canopy connection. Exhaust air from Types B1 and B2 BSCs must be discharged to the outdoors via a hard connection.

HEPA filters are effective at trapping particulates and thus infectious agents but do not capture volatile chemicals or gases. Only Type A2-exhausted or Types B1 and B2 BSCs exhausting to the outside should be used when working with volatile, toxic chemicals, but amounts must be limited (See Table 2).

All Class II cabinets are designed for work involving microorganisms assigned to biosafety levels 1, 2 and 3.¹ Class II BSCs provide the microbe-free work environment necessary for cell culture propagation and also may be used for the formulation of nonvolatile antineoplastic or chemotherapeutic drugs.⁹ Class II BSCs may be used with organisms requiring BSL-4 containment if used in a BSL-4 suit laboratory by a worker wearing a positive pressure protective suit.

1. The Class II, Type A1 BSC. An internal blower (Figure 3) draws sufficient room air through the front grille to maintain a minimum calculated or measured average inflow velocity of at least 75 lfpm at the face opening of the cabinet. The supply air flows through a HEPA filter and provides particulate-free air to the work surface. Laminar airflow reduces turbulence in the work zone and minimizes the potential for cross-contamination.

The downward moving air “splits” as it approaches the work surface; the blower draws part of the air to the front grille and the remainder to the rear grille. Although there are variations among different cabinets, this split generally occurs about halfway

Biological Safety Cabinets

between the front and rear grilles and two to six inches above the work surface.

The air is discharged through the front and rear grilles under negative air pressure into a blower and pushed into the space between the supply and exhaust filters. Due to the relative size of these two filters, approximately 30% of the air passes through the exhaust HEPA filter and 70% recirculates through the supply HEPA filter back into the work zone. Most Class II, Type A1 and A2 cabinets have dampers to modulate this division of airflow.

A Class II Type A1 BSC is not to be used for work involving volatile toxic chemicals. The buildup of chemical vapors in the cabinet (by recirculated air) and in the laboratory (from exhaust air) could create health and safety hazards (See Section IV).

It is possible to exhaust the air from a Type A1 or A2 cabinet outside of the building. However, it must be done in a manner that does not alter the balance of the cabinet exhaust system, and thereby disturbing the internal cabinet airflow. The proper method of connecting a Type A1 or A2 cabinet to the building exhaust system is through use of a canopy hood,^{8,10} which provides a small opening or air gap (usually 1 inch) around the cabinet exhaust filter housing (Figure 4). The airflow of the building exhaust must be sufficient to maintain the flow of room air into the gap between the canopy unit and the filter housing.^a The canopy must be removable or be designed to allow for operational testing of the cabinet (See Section VI). Class II Type A1 or A2 cabinets should never be hard-ducted to the building exhaust system.⁸ Fluctuations in air volume and pressure that are common to all building exhaust systems make it difficult to match the airflow requirements of the cabinet. Existing Class II Type A1 or A2 hard ducted exhaust connections can be altered and the room air balanced to allow for the recommended air gap inflows to avoid fluctuations in airflow. This may require added building exhaust system capacity.

2. The Class II, Type B1 BSC. Some biomedical research requires the use of small quantities of hazardous chemicals, such

^aContact manufacturers for any additional specifications.

Biological Safety Cabinets

as carcinogens. The powdered form of these carcinogens should be weighed or manipulated in a chemical fume hood or a static-air glove box equipped with a double-door airlock. Carcinogens used in cell culture or microbial systems require both biological and chemical containment.¹¹

The Class II, Type B cabinet originated with the National Cancer Institute (NCI)-designed Type 2¹² (later called Type B) BSC (Figure 5A), and was designed for manipulations of minute quantities of these hazardous chemicals with in vitro biological systems. The NSF International NSF/ANSI Standard 49 - 2002 definition of Type B1 cabinets⁸ includes this classic NCI design Type B, as well as cabinets without supply HEPA filters located immediately below the work surface (Figure 5B), and/or those with exhaust/recirculation downflow splits other than exactly 70/30%.

The cabinet supply blowers draw room air (plus a portion of the cabinet's recirculated air) through the front grille and through the supply HEPA filters located immediately below the work surface. This particulate-free air flows upward through a plenum at each side of the cabinet and then downward to the work area through a back-pressure plate. In some cabinets there is an additional supply HEPA filter to remove particulates that may be generated by the blower-motor system.

Room air is drawn through the face opening of the cabinet at a minimum measured inflow velocity of 100 lfpm. As with the Type A1 and A2 cabinets, there is a split in the down-flowing air stream just above the work surface. In the Type B1 cabinet, approximately 70 percent of the downflow air exits through the rear grille, passes through the exhaust HEPA filter, and is discharged from the building. The remaining 30 percent of the downflow air is drawn through the front grille. Since the air which flows to the rear grille is discharged into the exhaust system, activities that may generate hazardous chemical vapors or particulates should be conducted towards the rear of the cabinet work area.¹³

Type B1 cabinets must be hard-ducted, preferably to a dedicated, independent exhaust system, or to a properly-

Biological Safety Cabinets

designed laboratory building exhaust. As indicated earlier, fans for laboratory exhaust systems should be located at the terminal end of the duct work. A failure in the building exhaust system may not be apparent to the user, as the supply blowers in the cabinet will continue to operate. A pressure-independent monitor and alarm should be installed to provide warning and shut off the BSC supply fan, should failure in exhaust airflow occur. Since this feature is not supplied by all cabinet manufacturers, it is prudent to install a sensor such as a flow monitor and alarm in the exhaust system as necessary. To maintain critical operations, laboratories using Type B1 BSCs should connect the exhaust blower to the emergency power supply.

3. The Class II, Type B2 BSC. This BSC is a total-exhaust cabinet; no air is recirculated within it (Figure 6). This cabinet provides simultaneous primary biological and chemical containment. Consideration must be given to the chemicals used in BSCs as some chemicals can destroy the filter medium, housings and/or gaskets causing loss of containment. The supply blower draws either room or outside air in at the top of the cabinet, passes it through a HEPA filter and down into the work area of the cabinet. The building exhaust system draws air through both the rear and front grills, capturing the supply air plus the additional amount of room air needed to produce a minimum calculated or measured inflow face velocity of 100 lfpm. All air entering this cabinet is exhausted, and passes through a HEPA filter (and perhaps some other air-cleaning device such as a carbon filter if required for the work being performed) prior to discharge to the outside. This cabinet exhausts as much as 1200 cubic feet per minute of conditioned room air making this cabinet expensive to operate. The higher static air pressure required to operate this cabinet also results in additional costs associated with heavier gauge ductwork and higher capacity exhaust fan. Therefore the need for the Class II, Type B2 should be justified by the research to be conducted.

Should the building exhaust system fail, the cabinet will be pressurized, resulting in a flow of air from the work area back into the laboratory. Cabinets built since the early 1980's usually have an interlock system, installed by the manufacturer, to prevent

Biological Safety Cabinets

the supply blower from operating whenever the exhaust flow is insufficient; systems can be retrofitted if necessary. Exhaust air movement should be monitored by a pressure-independent device, such as a flow monitor.

4. The Class II, Type A2 BSC (Formerly called A/B3). Only when this BSC (Figure 7) is ducted to the outdoors does it meet the requirements of the former Class II Type B3.⁸ The Type A2 cabinet has a minimum calculated or measured inflow velocity of 100 lfpm. All positive pressure biologically contaminated plenums within the cabinet are surrounded by a negative air pressure plenum thus ensuring that any leakage from a contaminated plenum will be drawn into the cabinet and not released to the environment. Minute quantities of volatile toxic chemicals or radionuclides can be used in a Type A2 cabinet only if it exhausts to the outside via a properly functioning canopy connection.⁸

5. Special applications. Class II BSCs can be modified to accommodate special tasks. For example, the front sash can be modified by the manufacturer to accommodate the eye pieces of a microscope, or the work surface can be designed to accept a carboy, a centrifuge or other equipment that may require containment. A rigid plate with openings for the arms can be added if needed. Good cabinet design, microbiological aerosol tracer testing of the modification and appropriate certification (See Section VII) are required to ensure that the basic systems operate properly after modification. Maximum containment potential is achieved only through strict adherence to proper practices and procedures (See Section V).

The Class III BSC

The Class III BSC (Figure 8) was designed for work with highly infectious microbiological agents and for the conduct of hazardous operations and provides maximum protection for the environment and the worker. It is a gas-tight (no leak greater than 1×10^{-7} cc/sec with 1% test gas at 3 inches pressure Water Gauge¹⁴) enclosure with a non-opening view window. Access for passage of materials into the cabinet is through a dunk tank, that is accessible through the cabinet floor, or

Biological Safety Cabinets

double-door pass-through box (e.g., an autoclave) that can be decontaminated between uses. Reversing that process allows materials to be removed from the Class III BSC safely. Both supply and exhaust air are HEPA filtered on a Class III cabinet. Exhaust air must pass through two HEPA filters, or a HEPA filter and an air incinerator, before discharge to the outdoors. Airflow is maintained by an exhaust system exterior to the cabinet, which keeps the cabinet under negative pressure (minimum of 0.5 inches of water gauge.) “The exhaust fan for the Class III cabinet is generally separate from the exhaust fans of the facility ventilation system.”¹⁶

Long, heavy-duty rubber gloves are attached in a gas-tight manner to ports in the cabinet and allow direct manipulation of the materials isolated inside. Although these gloves restrict movement, they prevent the user’s direct contact with the hazardous materials. The trade-off is clearly on the side of maximizing personal safety. Depending on the design of the cabinet, the supply HEPA filter provides particulate-free, albeit somewhat turbulent, airflow within the work environment. Laminar air-flow is not a characteristic of a Class III cabinet.

Several Class III BSCs can be joined together in a “line” to provide a larger work area. Such cabinet lines are custom-built; the equipment installed in the cabinet line (e.g., refrigerators, small elevators, shelves to hold small animal cage racks, microscopes, centrifuges, incubators, etc.) is generally custom-built as well.

Horizontal Laminar Flow “Clean Bench”

Horizontal laminar flow “clean benches” (Figure 9A) are not BSCs. These pieces of equipment discharge HEPA-filtered air from the back of the cabinet across the work surface and toward the user. These devices only provide product protection. They can be used for certain clean activities, such as the dust-free assembly of sterile equipment or electronic devices. Clean benches should never be used when handling cell culture materials or drug formulations, or when manipulating potentially infectious materials. The worker will be exposed to the materials

Biological Safety Cabinets

being manipulated on the clean bench potentially resulting in hypersensitivity, toxicity or infection depending on the materials being handled. Horizontal airflow “clean benches” must never be used as a substitute for a biological safety cabinet. Users must be aware of the differences between these two devices.

Vertical Laminar Flow “Clean Bench”.

Vertical laminar flow clean benches (Figure 9B) also are not BSCs. They may be useful, for example, in hospital pharmacies when a clean area is needed for preparation of intravenous solutions. While these units generally have a sash, the air is usually discharged into the room under the sash, resulting in the same potential problems presented by the horizontal laminar flow clean benches. These benches should never be used for the manipulation of potentially infectious or toxic materials.

SECTION IV

Other Laboratory Hazards and Risk Assessment

Primary containment is an important strategy in minimizing exposure to the many chemical, radiological and biological hazards encountered in the laboratory. An overview is provided, in Table 2, of the various classes of BSCs, the level of containment afforded by each and the appropriate risk assessment considerations. Microbiological risk assessment is addressed in depth in BMBL.¹

Working with Chemicals in BSCs

Work with infectious microorganisms often requires the use of various chemical agents, and many commonly used chemicals vaporize easily. Therefore, evaluation of the inherent hazards of the chemicals must be part of the risk assessment when selecting a BSC. Flammable chemicals should not be used in Class II, Type A1 or A2 cabinets since vapor buildup inside the cabinet presents a fire hazard. In order to determine the greatest chemical concentration which might be entrained in the air stream following an accident or spill, it is necessary to evaluate the quantities to be used. Mathematical models are available to assist in these determinations.¹³ For more information regarding the risks associated with exposure to chemicals, the reader should consult the Threshold Limit Values (TLVs) for various chemical substances established by the American Conference of Governmental Industrial Hygienists.¹⁵

The electrical systems of Class II BSCs are not spark-proof. Therefore, a chemical concentration approaching the lower explosive limits of the compound must be prohibited. Furthermore, since non-exhausted Class II, Type A1 and A2 cabinets return chemical vapors to the cabinet work space and the room, they may expose the operator and other room occupants to toxic chemical vapors.

A chemical fume hood should be used for procedures using volatile chemicals instead of a BSC. Chemical fume hoods

Laboratory Hazards and Risk Assessment

are connected to an independent exhaust system and operate with single-pass air discharged, directly or through a manifold, outside the building. They may also be used when manipulating chemical carcinogens.¹¹ When manipulating small quantities of volatile toxic chemicals required for use in microbiological studies, Class I and Class II (Type B2) BSCs, exhausted to the outdoors, can be used. The Class II, Type B1 and A2 canopy-exhausted cabinets may be used with minute or tracer quantities of nonvolatile toxic chemicals.⁸

Many liquid chemicals, including nonvolatile antineoplastic agents, chemotherapeutic drugs and low-level radionuclides, can be safely handled inside Class II, Type A cabinets.⁹ Class II BSCs should not be used for labeling of biohazardous materials with radioactive iodine. Hard-ducted, ventilated containment devices incorporating both HEPA and charcoal filters in the exhaust systems are necessary for the conduct of this type of work (Figure 10).

Many virology and cell culture laboratories use diluted preparations of chemical carcinogens^{11,16} and other toxic substances. Prior to maintenance, careful evaluation must be made of potential problems associated with decontaminating the cabinet and the exhaust system. Air treatment systems, such as a charcoal filter in a bag-in/bag-out housing,¹⁷ (Figure 13) may be required so that discharged air meets applicable emission regulations.

Recommendations from the former Office of Research Safety of the NCI¹⁸ stated that work involving the use of chemical carcinogens for in vitro procedures can be performed in a Class II cabinet which meets the following parameters: 1) exhaust airflow is sufficient to provide a minimum inward velocity of 100 lfpm at the face opening of the cabinet; 2) contaminated air plenums under positive pressure are leak-tight; and 3) cabinet air is discharged to the outdoors. National Sanitation Foundation (NSF)/ANSI 49 - 2002⁸ currently recommends that biologically-contaminated ducts and plenums of Class II, Type A2 and B cabinets be maintained under negative air pressure, or surrounded by negative pressure ducts and plenums and be exhausted to the outdoors.

Laboratory Hazards and Risk Assessment

Radiological Hazards in the BSC

As indicated above, volatile radionuclides such as I^{125} should not be used within Class II BSCs. When using nonvolatile radionuclides inside a BSC, the same hazards exist as if working with radioactive materials on the bench top. Work that has the potential for splatter or creation of aerosols can be done within the BSC. Radiologic monitoring must be performed. A straight, vertical (not sloping) beta shield may be used inside the BSC to provide worker protection. A sloping shield can disrupt the air curtain and increase the possibility of contaminated air being released from the cabinet. A radiation safety professional should be contacted for specific guidance.

Risk Assessment

The potential for untoward events must be evaluated to eliminate or reduce to the greatest extent possible worker exposure to infectious organisms and to prevent release to the environment. Agent summary statements detailed in BMBL¹ provide data for microorganisms known to have caused laboratory-associated infections that may be used in protocol-driven risk assessment. Through the process of risk assessment, the laboratory environment and the work to be conducted are evaluated to identify hazards and develop interventions to ameliorate risks.

A properly certified and operational BSC is an effective engineering control (See Section VI) which must be used in concert with the appropriate practices, procedures and other administrative controls to further reduce the risk of exposure to potentially infectious microorganisms. Suggested work practices and procedures for minimizing risks when working in a BSC are detailed in the next section.

SECTION V

BSC Use by the Investigator: Work Practices and Procedures

Preparing for Work Within a Class II BSC

Preparing a written checklist of materials necessary for a particular activity and placing necessary materials in the BSC before beginning work serves to minimize the number and extent of air curtain disruptions compromising the fragile air barrier of the cabinet. The rapid movement of a worker's arms in a sweeping motion into and out of the cabinet will disrupt the air curtain and compromise the partial containment barrier provided by the BSC. Moving arms in and out slowly, perpendicular to the face opening of the cabinet will reduce this risk. Other personnel activities in the room (e.g., rapid movements near the face of the cabinet, walking traffic, room fans, open/closing room doors, etc.) may also disrupt the cabinet air barrier.⁶

Laboratory coats should be worn buttoned over street clothing; latex, vinyl, nitrile or other suitable gloves are worn to provide hand protection. Increasing levels of PPE can be included as determined by an individual risk assessment. For example, a solid front, back-closing laboratory gown provides better protection of personal clothing than a traditional laboratory coat and is a recommended practice at BSL-3.

Before beginning work, the investigator should adjust the stool height so that his/her face is above the front opening. Manipulation of materials should be delayed for approximately one minute after placing the hands/arms inside the cabinet. This allows the cabinet to stabilize, to "air sweep" the hands and arms, and to allow time for turbulence reduction. When the user's arms rest flatly across the front grille, occluding the grille opening, room air laden with particles may flow directly into the work area, rather than being drawn down through the front grille. Raising the arms slightly will alleviate this problem. The front grille must not be blocked with toweling, research notes, discarded plastic wrappers, pipetting devices, etc. All operations

BSC Use: Work Practices and Procedures

should be performed on the work surface at least four inches in from the front grille. If there is a drain valve under the work surface, it should be closed prior to beginning work in the BSC.

Materials or equipment placed inside the cabinet may cause disruption of the airflow, resulting in turbulence, possible cross-contamination and/or breach of containment. Extra supplies (e.g., additional gloves, culture plates or flasks, culture media) should be stored outside the cabinet. Only the materials and equipment required for the immediate work should be placed in the BSC.

BSCs are designed for 24 hours per day operation and some investigators find that continuous operation helps to control the laboratory's level of dust and other airborne particulates. Although energy conservation may suggest BSC operation only when needed, especially if the cabinet is not used routinely, room air balance is an overriding consideration. Air discharged through ducted BSCs must be considered in the overall air balance of the laboratory.

If the cabinet has been shut down, the blowers should be operated at least four minutes before beginning work to allow the cabinet to "purge." This purge will remove any suspended particulates in the cabinet. The work surface, the interior walls (except the supply filter diffuser), and the interior surface of the window should be wiped with 70% ethanol (EtOH), a 1:100 dilution of household bleach (i.e., 0.05% sodium hypochlorite), or other disinfectant as determined by the investigator to meet the requirements of the particular activity. When bleach is used, a second wiping with sterile water is needed to remove the residual chlorine, which may eventually corrode stainless steel surfaces. Wiping with non-sterile water may recontaminate cabinet surfaces, a critical issue when sterility is essential (e.g., maintenance of cell cultures).

Similarly, the surfaces of all materials and containers placed into the cabinet should be wiped with 70% EtOH to reduce the introduction of contaminants to the cabinet environment. This simple step will reduce introduction of mold spores and

BSC Use: Work Practices and Procedures

thereby minimize contamination of cultures. Further reduction of microbial load on materials to be placed or used in BSCs may be achieved by periodic decontamination of incubators and refrigerators.

Material Placement Inside the BSC

Plastic-backed absorbent toweling can be placed on the work surface but not on the front or rear grille openings. The use of toweling facilitates routine cleanup and reduces splatter and aerosol generation¹⁹ during an overt spill. It can be folded and placed in a biohazard bag or other appropriate receptacle when work is completed.

All materials should be placed as far back in the cabinet as practical, toward the rear edge of the work surface and away from the front grille of the cabinet (Figure 11). Similarly, aerosol-generating equipment (e.g., vortex mixers, tabletop centrifuges) should be placed toward the rear of the cabinet to take advantage of the air split described in Section III. Bulky items such as biohazard bags, discard pipette trays and vacuum collection flasks should be placed to one side of the interior of the cabinet. If placing those items in the cabinet requires opening the sash, make sure that the sash is returned to its original position before work is initiated. The correct sash position (usually 8" or 10" above the base of the opening) should be indicated on the front of the cabinet. On most BSCs an audible alarm will sound if the sash is in the wrong position while the fan is operating.

Certain common practices interfere with the operation of the BSC. The biohazard collection bag should not be taped to the outside of the cabinet. Upright pipette collection containers should not be used in BSCs nor placed on the floor outside the cabinet. The frequent inward/outward movement needed to place objects in these containers is disruptive to the integrity of the cabinet air barrier and can compromise both personnel and product protection. Only horizontal pipette discard trays containing an appropriate chemical disinfectant should be used within the cabinet. Furthermore, potentially contaminated

BSC Use: Work Practices and Procedures

materials should not be brought out of the cabinet until they have been surface decontaminated. Alternatively, contaminated materials can be placed into a closable container for transfer to an incubator, autoclave or another part of the laboratory.

Operations Within a Class II BSC

Laboratory Hazards

Many procedures conducted in BSCs may create splatter or aerosols. Good microbiological techniques should always be used when working in a BSC. For example, techniques used to reduce splatter and aerosol generation will also minimize the potential for personnel exposure to infectious materials manipulated within the cabinet. Class II cabinets are designed so that horizontally nebulized spores introduced into the cabinet will be captured by the downward flowing cabinet air within fourteen inches⁸ of travel. Therefore, as a general rule of thumb, keeping clean materials at least one foot away from aerosol-generating activities will minimize the potential for cross-contamination.

The work flow should be from “clean to dirty” (See Figure 11). Materials and supplies should be placed in the cabinet in such a way as to limit the movement of “dirty” items over “clean” ones.

Several measures can be taken to reduce the chance for cross-contamination of materials when working in a BSC. Opened tubes or bottles should not be held in a vertical position. Investigators working with Petri dishes and tissue culture plates should hold the lid above the open sterile surface to minimize direct impaction of downward air. Bottle or tube caps should not be placed on the toweling. Items should be recapped or covered as soon as possible.

Open flames are not required in the near microbe-free environment of a biological safety cabinet. On an open bench, flaming the neck of a culture vessel will create an upward air current which prevents microorganisms from falling into the tube or flask. An open flame in a BSC, however, creates turbulence which disrupts the pattern of HEPA-filtered air being supplied to

BSC Use: Work Practices and Procedures

the work surface. When deemed absolutely necessary, touch-plate microburners equipped with a pilot light to provide a flame on demand may be used. Internal cabinet air disturbance and heat buildup will be minimized. The burner must be turned off when work is completed. Small electric “furnaces” are available for decontaminating bacteriological loops and needles and are preferable to an open flame inside the BSC. Disposable or recyclable sterile loops should be used whenever possible.

Aspirator bottles or suction flasks should be connected to an overflow collection flask containing appropriate disinfectant, and to an in-line HEPA or equivalent filter (See Figure 12). This combination will provide protection to the central building vacuum system or vacuum pump, as well as to the personnel who service this equipment. Inactivation of aspirated materials can be accomplished by placing sufficient chemical decontamination solution into the flask to inactivate the microorganisms as they are collected. Once inactivation occurs, liquid materials can be disposed of as noninfectious waste.

Investigators must determine the appropriate method of decontaminating materials that will be removed from the BSC at the conclusion of the work. When chemical means are appropriate, suitable liquid disinfectant should be placed into the discard pan before work begins. Items should be introduced into the pan with minimum splatter and allowed appropriate contact time as per manufacturer’s instructions. Alternatively, liquids can be autoclaved prior to disposal. Contaminated items should be placed into a biohazard bag, discard tray, or other suitable container prior to removal from the BSC.

When a steam autoclave is to be used, contaminated materials should be placed into a biohazard bag or discard pan containing enough water to ensure steam generation during the autoclave cycle. The bag should be taped shut or the discard pan should be covered in the BSC prior to transfer to the autoclave. The bag should be transported and autoclaved in a leak proof tray or pan. It is a prudent practice to decontaminate the exterior surface of bags and pans just prior to removal from the cabinet.

Decontamination

Cabinet Surface Decontamination

With the cabinet blower running, all containers and equipment should be surface decontaminated and removed from the cabinet when work is completed. At the end of the work day, the final surface decontamination of the cabinet should include a wipe-down of the work surface, the cabinet's sides and back and the interior of the glass. If necessary, the cabinet should also be monitored for radioactivity and decontaminated when necessary. Investigators should remove their gloves and gowns in a manner to prevent contamination of unprotected skin and aerosol generation and wash their hands as the final step in safe microbiological practices. The cabinet blower may be turned off after these operations are completed, or left on.

Small spills within the operating BSC can be handled immediately by removing the contaminated absorbent paper toweling and placing it into the biohazard bag or receptacle. Any splatter onto items within the cabinet, as well as the cabinet interior, should be immediately cleaned up with a towel dampened with an appropriate decontaminating solution. Gloves should be changed after the work surface is decontaminated and before placing clean absorbent toweling in the cabinet. Hands should be washed whenever gloves are changed or removed.

Spills large enough to result in liquids flowing through the front or rear grilles require more extensive decontamination. All items within the cabinet should be surface decontaminated and removed. After ensuring that the drain valve is closed, decontaminating solution can be poured onto the work surface and through the grille(s) into the drain pan.

Twenty to thirty minutes is generally considered an appropriate contact time for decontamination, but this varies with the disinfectant and the microbiological agent. Manufacturer's directions should be followed. The spilled fluid and disinfectant solution on the work surface should be absorbed with paper towels and discarded into a biohazard bag. The drain pan should be emptied into a collection vessel containing disinfectant. A

Facilities and Engineering Requirements

hose barb and flexible tube should be attached to the drain valve and be of sufficient length to allow the open end to be submerged in the disinfectant within the collection vessel. This procedure serves to minimize aerosol generation. The drain pan should be flushed with water and the drain tube removed.

Should the spilled liquid contain radioactive material, a similar procedure can be followed. Radiation safety personnel should be contacted for specific instructions.

Periodic removal of the cabinet work surface and/or grilles after the completion of drain pan decontamination may be justified because of dirty drain pan surfaces and grilles, which ultimately could occlude the drain valve or block airflow. However, extreme caution should be observed on wiping these surfaces to avoid injury from broken glass that may be present and sharp metal edges. Always use disposable paper toweling and avoid applying harsh force. Wipe dirty surfaces gently. Never leave toweling on the drain pan because the paper could block the drain valve or the air passages in the cabinet.

Gas Decontamination

BSCs that have been used for work involving infectious materials must be decontaminated before HEPA filters are changed or internal repair work is done.²⁰⁻²³ Before a BSC is relocated, a risk assessment considering the agents manipulated within the BSC must be performed to determine the need and method for decontamination. The most common decontamination method uses formaldehyde gas, although more recently, hydrogen peroxide vapor²¹ and chlorine dioxide gas have been used successfully.

SECTION VI

Facility and Engineering Requirements

Secondary Barriers

Whereas BSCs are considered to be the primary safety barrier for manipulation of infectious materials, the laboratory room itself is considered to be the secondary safety barrier.²⁴ Inward directional airflow is established²⁵ by exhausting a greater volume of air than is supplied to a given laboratory and by drawing makeup air from the adjacent space. This is optional at BSL-2 but must be maintained at BSL-3.^{1,26} The air balance for the entire facility should be established and maintained to ensure that airflow is from areas of least - to greater potential contamination.

Building Exhaust

At BSL-3 and BSL-4, exhaust laboratory air must be directly exhausted to the outside since it is considered potentially contaminated. This concept is referred to as a dedicated, single-pass exhaust system. The exhausted room air can be HEPA-filtered when a high level of aerosol containment is needed, which is always true at BSL-4 and may be optional at BSL-3. When the building exhaust system is used to vent a ducted BSC, the system must have sufficient capacity to maintain the exhaust flow if changes in the static pressure within the system should occur. Otherwise, each cabinet must have a dedicated exhaust system. The connection to a BSC must be constant air volume (CAV). Variable air volume (VAV) on a BSC exhaust must be avoided.

The room exhaust system should be sized to handle both the room and all containment devices vented through the system. Adequate supply air must be provided to ensure appropriate function of the exhaust system. The facility engineer must be consulted before locating a new cabinet requiring connection to the building exhaust system. Right angle bends, long horizontal runs and transitional connections within the systems will add to the demand on the exhaust fan. The building exhaust air should

Facilities and Engineering Requirements

be discharged away from supply air intakes, to prevent re-entrainment of laboratory exhaust air into the building air supply system. Refer to recognized design guides for locating the exhaust terminus relative to nearby air intakes.²⁷

Utility Services

Utility services needed within a BSC must be planned carefully. Protection of vacuum systems must be addressed (Figure 12). Electrical outlets inside the cabinet must be protected by ground fault circuit interrupters and should be supplied by an independent circuit. When propane or natural gas is provided, a clearly marked emergency gas shut-off valve outside the cabinet must be installed for fire safety. All non-electrical utility services should have exposed, accessible shut-off valves. The use of compressed air within a BSC must be carefully considered and controlled to prevent aerosol production and reduce the potential for vessel pressurization.

Ultraviolet Lamps

Ultraviolet (UV) lamps are not required in BSCs nor are they necessary. If installed, UV lamps must be cleaned weekly to remove any dust and dirt that may block the germicidal effectiveness of the ultraviolet light. The lamps should be checked weekly with a UV meter to ensure that the appropriate intensity of UV light is being emitted. UV lamps must be turned off when the room is occupied to protect eyes and skin from UV exposure, which can burn the cornea and cause skin cancer. If the cabinet has a sliding sash, close the sash when operating the UV lamp.

BSC Placement

BSCs were developed (See Section I) as work stations to provide personnel, environmental and product protection during the manipulation of infectious microorganisms. Certain considerations must be met to ensure maximum effectiveness of these primary barriers. Whenever possible, adequate clearance should be provided behind and on each side of the cabinet

Facilities and Engineering Requirements

to allow easy access for maintenance and to ensure that the cabinet air re-circulated to the laboratory is not hindered. A 12 to 14 inch clearance above the cabinet may be required to provide for accurate air velocity measurement across the exhaust filter surface^{28,29} and for exhaust filter changes. When the BSC is hard-ducted or connected by a canopy unit to the ventilation system, adequate space must be provided so that the configuration of the duct work will not interfere with airflow. The canopy unit must provide adequate access to the exhaust HEPA filter for testing.

The ideal location for the biological safety cabinet is remote from the entry (i.e., the rear of the laboratory away from traffic), since people walking parallel to the face of a BSC can disrupt the air curtain.^{16,20,30} The air curtain created at the front of the cabinet is quite fragile, amounting to a nominal inward and downward velocity of 1 mph. Open windows, air supply registers, portable fans or laboratory equipment that creates air movement (e.g., centrifuges, vacuum pumps) should not be located near the BSC. Similarly, chemical fume hoods must not be located close to BSCs.

HEPA Filters

HEPA filters, whether part of a building exhaust system or part of a cabinet, will require replacement when they become loaded to the extent that sufficient airflow can no longer be maintained. In most instances, filters must be decontaminated before removal. To contain the formaldehyde gas typically used for microbiological decontamination, exhaust systems containing HEPA filters require airtight dampers to be installed on both the inlet and discharge side of the filter housing. This ensures containment of the gas inside the filter housing during decontamination. Access panel ports in the filter housing also allow for performance testing of the HEPA filter (See Section VII).

A bag-in/bag-out filter assembly^{3,17} (Figure 13) can be used in situations where HEPA filtration is necessary for operations involving biohazardous materials and hazardous or toxic chemicals. The bag-in/bag-out system is used when it is not possible to gas or vapor decontaminate the HEPA filters, or

Facilities and Engineering Requirements

when hazardous chemicals or radionuclides have been used in the BSC, and provides protection against exposure for the maintenance personnel and the environment. Note, however, that this requirement must be identified at the time of purchase and installation; a bag-in/bag-out assembly cannot be added to a cabinet after-the-fact without an extensive engineering evaluation.

SECTION VII

Certification of BSCs

Development of Containment Standards

The evolution of containment equipment for varied research and diagnostic applications created the need for consistency in construction and performance. Federal Standard 209^{32,33}, was developed to establish classes of air cleanliness and methods for monitoring clean work stations and clean rooms where HEPA filters are used to control airborne particulates.

The first “standard” to be developed specifically for BSCs¹² served as a Federal procurement specification for the NIH Class II, Type 1 (now called Type A1) BSC, which had a fixed or hinged front window or a vertical sliding sash, vertical downward laminar airflow and HEPA-filtered supply and exhaust air. This guideline specified design criteria and defined prototype tests for microbiological aerosol challenge, velocity profiles, and leak testing of the HEPA filters. A similar procurement specification was generated³¹ when the Class II, Type 2 (now called Type B1) BSC was developed.

NSF Standard #49 for Class II BSCs was first published in 1976, providing the first independent standard for design, manufacture and testing of BSCs. This standard “replaced” the NIH specifications which were being used by other institutions and organizations purchasing BSCs. NSF/ANSI 49 – 2002, ⁸ incorporates current specifications regarding design, materials, construction, and testing. This Standard for BSCs establishes performance criteria and provides the minimum testing requirements that are accepted in the United States. Cabinets which meet the Standard and are certified by NSF bear an NSF Mark.

⁸ Federal Standard No. 209E9 has been replaced by ISO 14644. This standard does not apply to BSCs and should not be considered a basis for their performance or integrity certification. However, the methodology of ISO 14644 can be used to quantify the particle count within the work area of a BSC. ISO 14644 defines how to classify a clean room/clean zone. Performance tests and procedures needed to achieve a specified cleanliness classification are outlined by the Institute of Environmental Sciences and Technology's IEST-RP-CC-006.

Certification of Biosafety Cabinets

NSF/ANSI 49 – 2002 pertains to all models of Class II cabinets (Type A1, A2, B1, B2) and provides a series of specifications regarding:

- Design/construction
- Performance
- Installation recommendations
- Recommended microbiological decontamination procedure
- References and specifications pertinent to Class II Biosafety Cabinetry.

Annex F of NSF/ANSI 49 2002, which covers field testing of BSCs, is now a normative part of the Standard. This Standard is reviewed periodically by a committee of experts to ensure that it remains consistent with developing technologies.

The operational integrity of a BSC must be validated before it is placed into service and after it has been repaired or relocated. Relocation may break the HEPA filter seals or otherwise damage the filters or the cabinet. Each BSC should be tested and certified at least annually to ensure continued, proper operation.

On-site testing that follows the recommendations for field testing (NSF/ANSI 49 – 2002 Annex F plus Addendum #1) must be performed by experienced, qualified personnel. Some basic information is included in the Standard to assist in understanding the frequency and kinds of tests to be performed. In 1993, NSF began a program for accreditation of certifiers based on written and practical examinations. Education and training programs for persons seeking accreditation as qualified to perform all field certification tests are offered by a variety of organizations. Selecting competent individuals to perform testing and certification is important, and it is suggested that the institutional BSO be consulted in identifying companies qualified to conduct the necessary field performance tests.

^d The standard can be ordered of NSF for a nominal charge at NSF International, 789 North Dixboro Road, P.O. Box 130140, Ann Arbor, Michigan, 48113-0140. Telephone 734-769-8010; Fax 734-769-0190; E-mail: info@nsf.org; Telex 753215 NSF INTL

Certification of Biosafety Cabinets

It is strongly recommended that, whenever possible, accredited field certifiers are used to test and certify BSCs. If in-house personnel are performing the certifications, then these individuals should become accredited.

The annual tests applicable to each of the three classes of BSCs are listed in Table 3. Table 4 indicates where to find information regarding the conduct of selected tests. BSCs consistently perform well when proper annual certification procedures are followed; cabinet or filter failures tend to occur infrequently.

Performance Testing BSCs in the Field

Class II BSCs are the primary containment devices that protect the worker, product and environment from exposure to microbiological agents. BSC operation, as specified by NSF/ANSI 49 – 2002, Annex F plus Addendum #1 needs to be verified at the time of installation and annually thereafter. The purpose and acceptance level of the operational tests (Table 3) ensure the balance of inflow and exhaust air, the distribution of air onto the work surface, and the integrity of the cabinet and the filters. Other tests check electrical and physical features of the BSC.

A. Downflow Velocity and Volume Test: This test is performed to measure the velocity of air moving through the cabinet workspace, and is to be performed on all Class II BSCs.

B. Inflow Velocity Test: This test is performed to determine the calculated or directly measured velocity through the work access opening, to verify the nominal set point average inflow velocity and to calculate the exhaust airflow volume rate.

C. Airflow Smoke Patterns Test: This test is performed to determine if the airflow along the entire perimeter of the work access opening is inward, if airflow within the work area is downward with no dead spots or refluxing, if ambient air passes onto or over the work surface and if there is refluxing to the outside at the window wiper gasket and side seals. The smoke test is an indicator of airflow direction, not velocity.

Certification of Biosafety Cabinets

D. HEPA Filter Leak Test: This test is performed to determine the integrity of supply and exhaust HEPA filters, filter housing and filter mounting frames while the cabinet is operated at the nominal set point velocities. An aerosol in the form of generated particulates of dioctylphthalate (DOP) or an accepted alternative (e.g., poly alpha olefin (PAO), di(2-ethylhexyl) sebecate, polyethylene glycol and medical grade light mineral oil) is required for leak-testing HEPA filters and their seals. The aerosol is generated on the intake side of the filter and particles passing through the filter or around the seal are measured with a photometer on the discharge side. This test is suitable for ascertaining the integrity of all HEPA filters.

E. Cabinet Leak Test: This pressure holding test is performed to determine if exterior surfaces of all plenums, welds, gaskets and plenum penetrations or seals are free of leaks. In the field, it need only be performed on Type A1 cabinets just prior to initial installation when the BSC is in a free-standing position (all four sides are easily accessible) in the room in which it will be used, after a cabinet has been relocated to a new location and again after removal of access panels to plenums for repairs or a filter change. This test may also be performed on fully installed cabinets. Cabinet integrity can also be checked using the bubble test; liquid soap can be spread along welds, gaskets and penetrations to visualize air leaks that may occur.

F. Electrical Leakage and Ground Circuit Resistance and Polarity Tests: Electrical testing has been taken out of NSF/ANSI 49 – 2002 for new cabinets certified under the this Standard. This responsibility has been turned over to UL. All new cabinets must meet UL 61010A-1 in order to be certified by NSF. These safety tests are performed to determine if a potential shock hazard exists by measuring the electrical leakage, polarity, ground fault interrupter function and ground circuit resistance to the cabinet connection. They may be performed by an electrical technician other than the field certification personnel at the same time the other field certification tests are conducted. The polarity of electrical outlets is checked (See Table 3, E). The ground fault circuit interrupter should trip when approximately five milliamperes (mA) is applied.

Certification of Biosafety Cabinets

G. Lighting Intensity Test: This test is performed to measure the light intensity on the work surface of the cabinet as an aid in minimizing cabinet operator fatigue.

H. Vibration Test: This test is performed to determine the amount of vibration in an operating cabinet as a guide to satisfactory mechanical performance, as an aid in minimizing cabinet operator fatigue and to prevent damage to delicate tissue culture specimens.

I. Noise Level Test: This test is performed to measure the noise levels produced by the cabinets, as a guide to satisfactory mechanical performance and an aid in minimizing cabinet operator fatigue.

J. UV Lamp Test: A few BSCs have UV lamps. When used, they must be tested periodically to ensure that their energy output is sufficient to kill microorganisms. The surface on the bulb should be cleaned with 70% ethanol prior to performing this test. Five minutes after the lamp has been turned on, the sensor of the UV meter is placed in the center of the work surface. The radiation output should not be less than 40 microwatts per square centimeter at a wavelength of 254 nanometers (nm).

Finally, accurate test results can only be assured when the testing equipment is properly maintained and calibrated. It is appropriate to request the calibration information for the test equipment being used by the certifier.

TABLES

Table 1. Selection of a Safety Cabinet through Risk Assessment				
Biological Risk Assessed	Protection Provided			BSC Class
	Personnel	Product	Environmental	
BSL 1-3	Yes	No	Yes	I
BSL 1-3	Yes	Yes	Yes	II (A1,A2,B1,B2)
BSL 4	Yes	Yes	Yes	III II - When used in suitroom with suit

Table 2. Comparison of Biosafety Cabinet Characteristics				
BSC Class	Face Velocity	Airflow Pattern	Applications	
			Nonvolatile Toxic Chemicals and Radionuclides	Volatile Toxic Chemicals and Radionuclides
I	75	In at front through HEPA to the outside or into the room through HEPA (figure 2)	Yes	When exhausted outdoors ^{1,2}
II, A1	75	70% recirculated to the cabinet work area through HEPA; 30% balance can be exhausted through HEPA back into the room or to outside through a canopy unit (figure 3)	Yes (minute amounts)	No
II, B1	100	30% recirculated, 70% exhausted. Exhaust cabinet air must pass through a dedicated duct to the outside through a HEPA filter (figures 5A,5B)	Yes	Yes (minute amounts) ^{1,2}
II, B2	100	No recirculation; total exhaust to the outside through a HEPA filter (figure 6)	Yes	Yes (small amounts) ^{1,2}
II, A2	100	Similar to II, A1, but has 100 lfpm intake air velocity and plenums are under negative pressure to room; exhaust air can be ducted to the outside through a canopy unit (figure 7)	Yes	When exhausted outdoors (FORMALLY "B3") (minute amounts) ^{1,2}
III	N/A	Supply air is HEPA filtered. Exhaust air passes through two HEPA filters in series and is exhausted to the outside via a hard connection (figure 8)	Yes	Yes (small amounts) ^{1,2}

1. Installation may require a special duct to the outside, an in-line charcoal filter, and a spark proof (explosion proof) motor and other electrical components in the cabinet. Discharge of a Class I or Class II, Type A2 cabinet into a room should not occur if volatile chemicals are used.

2. In no instance should the chemical concentration approach the lower explosion limits of the compounds.

Table 3. Field Performance Tests to be Applied to the Three Classes of Biological Safety Cabinets

Test Performed for	Biosafety Cabinet		
	Class I	Class II	Class III
<u>Primary Containment</u>			
Cabinet integrity	N/A	A (A1 Only)	A
HEPA Filter Leak	Req	Req	Req
Downflow Velocity	N/A	Req	N/A
Face Velocity	Req	Req	N/A
Negative Pressure/Ventilation Rate	B	N/A	Req
Airflow Smoke Patterns	Req	Req	E/F
Alarms and Interlocks	C,D	C,D	Req
<u>Electrical Safety</u>			
Electrical Leakage, Etc.	E,D	E,D	E,D
Ground Fault Interrupter	D	D	D
<u>Other</u>			
Lighting Intensity	E	E	E
UV Intensity	C,E	C,E	C,E
Noise Level	E	E	E
Vibration	E	E	E

- Req Required during certification.
- A Required for proper certification if the cabinet is new, has been moved or panels have been removed for maintenance.
- B If used with gloves.
- C If present.
- D Encouraged for electrical safety.
- E Optional, at the discretion of the user.
- F Used to determine air distribution within cabinet for clean to dirty procedures.
- N/A Not applicable.

Table 4. Reference for Applicable Containment Tests			
Test	Cabinet Type by Class		
	I	II	III
HEPA Filter Leak	(F.5) ¹	(F.5)	(F.5)
Airflow Smoke Pattern	No smoke shall reflux out of BSC once drawn in.	(F.4)	N/A
Cabinet Integrity	N/A	(F.6)	[p.138-141] ²
Face Velocity Open Front	[75-125 lfpm]	75 lfpm - type A1; 100 lfpm type A2, B1& B2:(F.3)	N/A
Face Velocity Gloves Ports / No Gloves	150 lfpm	N/A	NA
Water Gauge Pressure Glove Ports & Gloves	N/A	N/A	(- 0.5 "w.c.) [p.145]
Downflow Velocity	N/A	(F.2)	N/A
1. Parenthetical references are to the NSF/ANSI Standard 49 2004, letters and numerals indicate specific sections and subsections.			
2. Bracketed reference ([])is to the Laboratory Safety Monograph, Page numbers are indicated.			

FIGURES

Figure 1. HEPA filters are typically constructed of paper-thin sheets of borosilicate medium, pleated to increase surface area, and affixed to a frame. Aluminum separators are often added for stability.

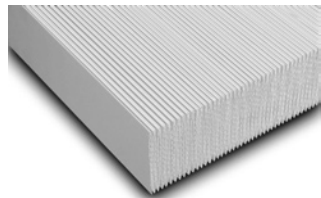
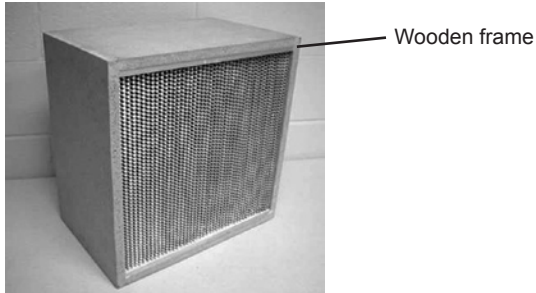
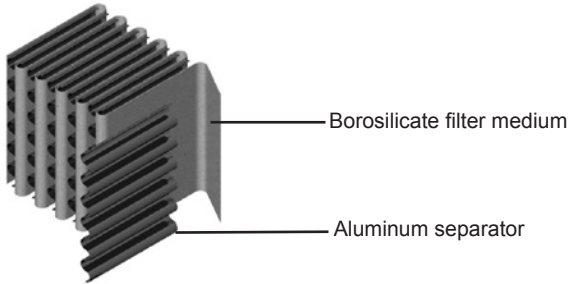

Continuous sheet of flat filter medium

Figure 2. The Class I BSC. A. front opening, B. sash, C. exhaust HEPA filter, D. exhaust plenum. Note: The cabinet needs to be hard connected to the building exhaust system if toxic vapors are to be used

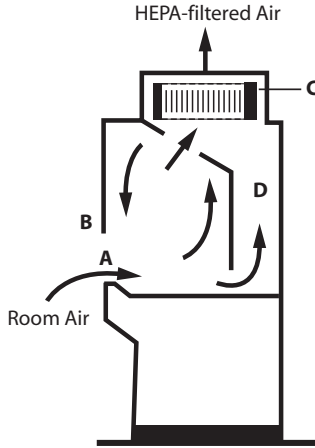

Figure 3. The Class II, Type A1 BSC. A. front opening, B. sash, C. exhaust HEPA filter, D. supply HEPA filter, E. common plenum, F. blower

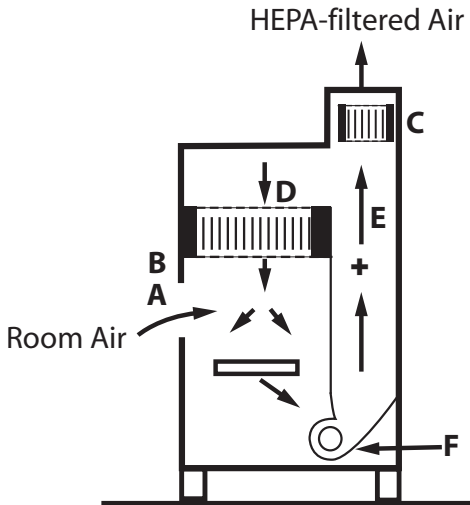

Figure 4. Canopy (thimble) unit for ducting a Class II, Type A BSC. A. balancing damper, B. flexible connector to exhaust system, C. cabinet exhaust HEPA filter housing, D. canopy unit, E. BSC. Note: There is a 1" gap between the canopy unit (D) and the exhaust filter housing (C), through which room air is exhausted.

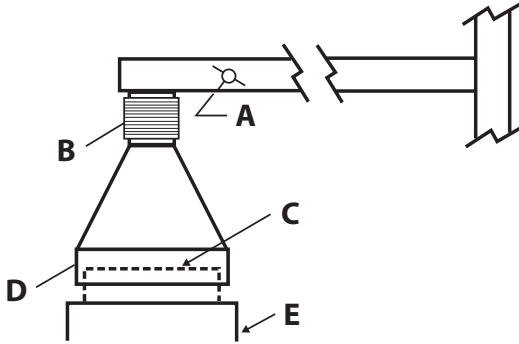

Figure 5A. The Class II, Type B1 BSC (classic design). A. front opening, B. sash, C. exhaust HEPA filter, D. supply HEPA filter, E. negative pressure dedicated exhaust plenum, F. blower, G. additional HEPA filter for supply air. Note: The cabinet exhaust needs to be hard connected to the building exhaust system.

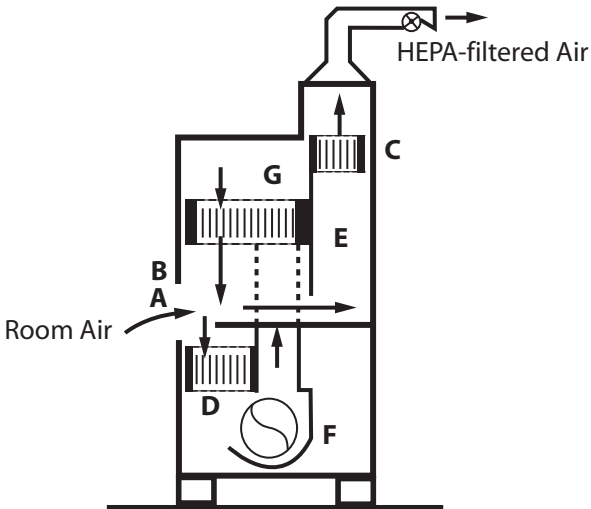

Figure 5B. The Class II, Type B1 BSC (bench top design). A. front opening, B. sash, C. exhaust HEPA filter, D. supply plenum, E. supply HEPA filter, F. blower, G. negative pressure exhaust plenum. Note: The cabinet exhaust needs to be hard connected to the building exhaust system.

Connection to building exhaust system required.

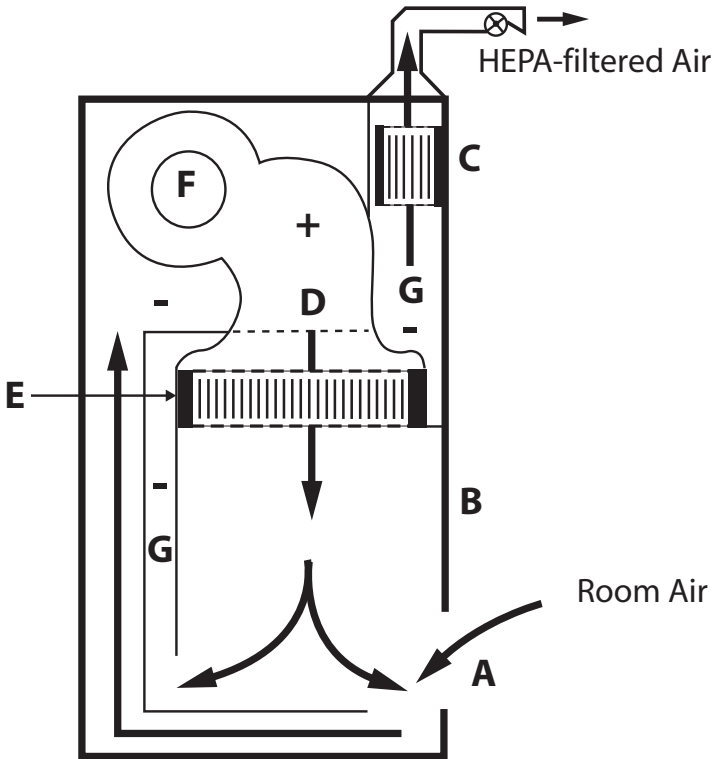

Figure 6. The Class II, Type B2 BSC. A. front opening, B. sash, C. exhaust HEPA filter, D. supply HEPA filter, E. negative pressure exhaust plenum. Note: The carbon filter in the exhaust system is not shown. The cabinet needs to be hard connected to the building exhaust system.

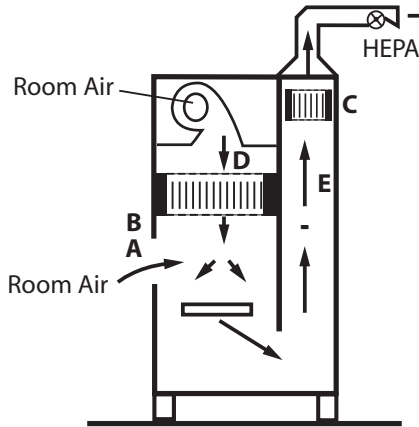

Figure 7. The tabletop model of a Class II, Type A2 BSC. A. front opening, B. sash, C. exhaust HEPA filter, D. supply HEPA filter, E. positive pressure common plenum, F. negative pressure plenum. The Class II Type A2 BSC is **not equivalent to what was formerly called a Class II Type B3 unless it is connected to the laboratory exhaust system.** Note: The A2 BSC should be canopy connected to the exhaust system.

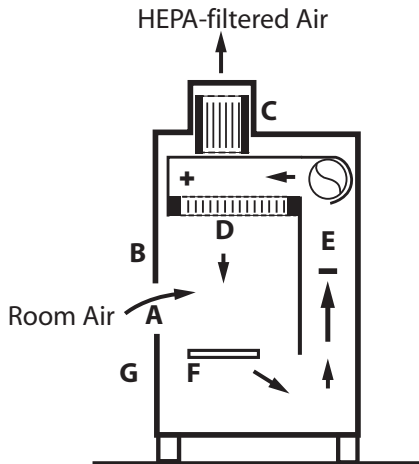

Figure 8. The Class III BSC. A. glove ports with O-ring for attaching arm-length gloves to cabinet, B. sash, C. exhaust HEPA filter, D. supply HEPA filter, E. double-ended autoclave or pass-through box. Note: A chemical dunk tank may be installed which would be located beneath the work surface of the BSC with access from above. The cabinet exhaust needs to be hard connected to an exhaust system where the fan is generally separate from the exhaust fans of the facility ventilation system. The exhaust air must be double HEPA filtered or HEPA filtered and incinerated.

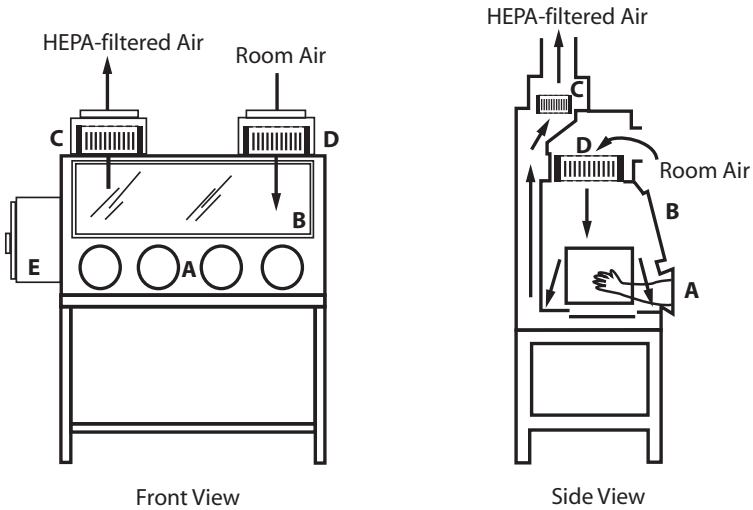

Figure 9A. The horizontal laminar flow “clean bench”. A. front opening, B. supply grille, C. supply HEPA filter, D. supply plenum, E. blower.

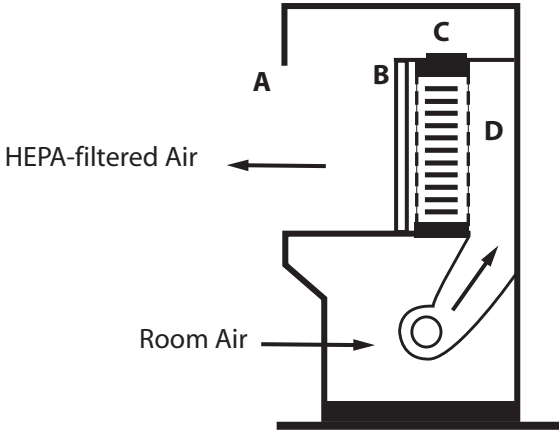

Figure 9B. The vertical laminar flow “clean bench”. A. front opening, B. sash, C. supply HEPA filter, D. blower. Note: Some vertical flow clean benches have recirculated air through front and/or rear perforated grilles.

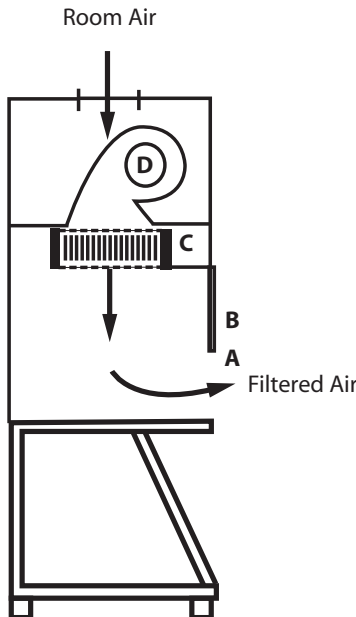

Figure 10. A modified containment cabinet or Class I BSC can be used for labeling infectious microorganisms with I^{125} . A. arm holes, B. Lexan[®] hinged doors, C. exhaust charcoal filter, D. exhaust HEPA filter, E. filter housing with required connection to building exhaust (see also Figure 13)

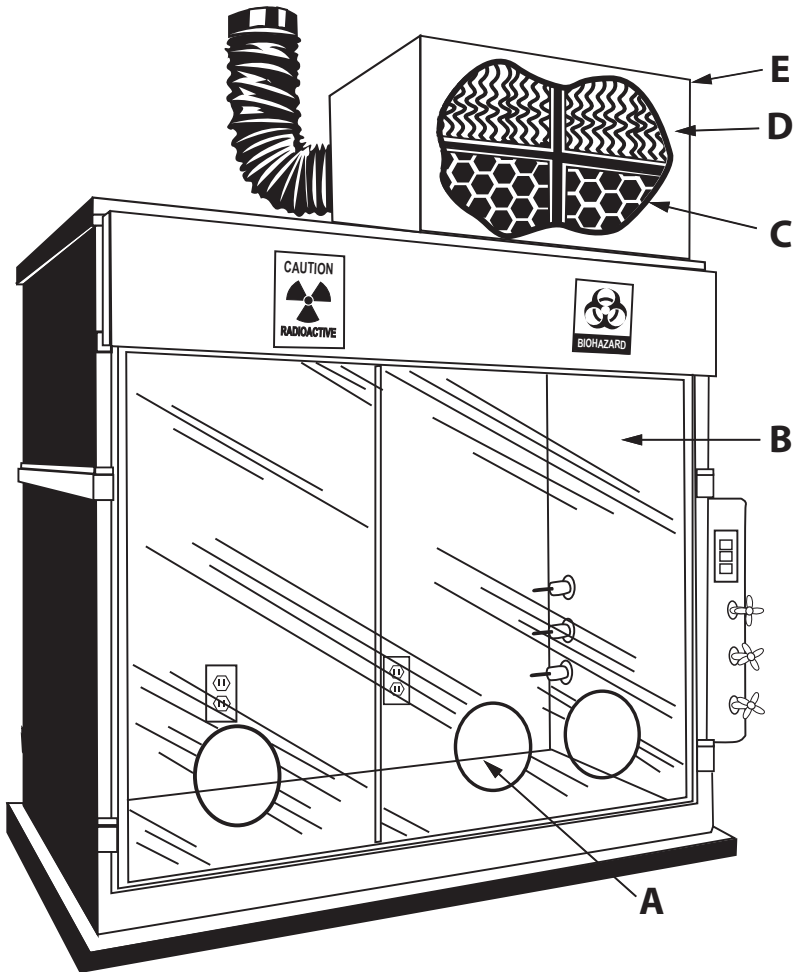

Figure 11. A typical layout for working “clean to dirty” within a Class II BSC. Clean cultures (left) can be inoculated (center); contaminated pipettes can be discarded in the shallow pan and other contaminated materials can be placed in the biohazard bag (right). This arrangement is reversed for left-handed persons.

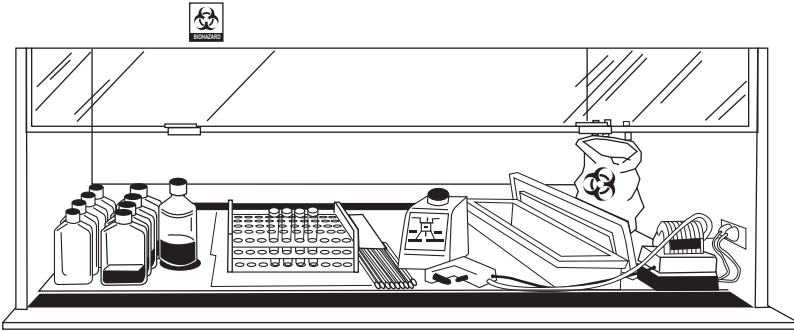

Figure 12. One method to protect a house vacuum system during aspiration of infectious fluids. The left suction flask (A) is used to collect the contaminated fluids into a suitable decontamination solution; the right flask (B) serves as a fluid overflow collection vessel. An in-line HEPA filter (C) is used to protect the vacuum system (D) from aerosolized microorganisms.

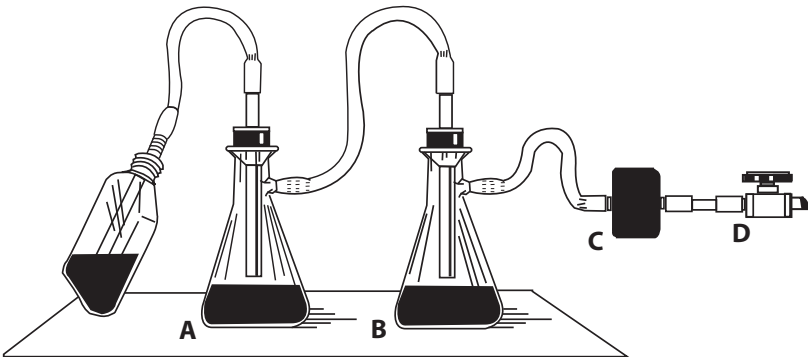
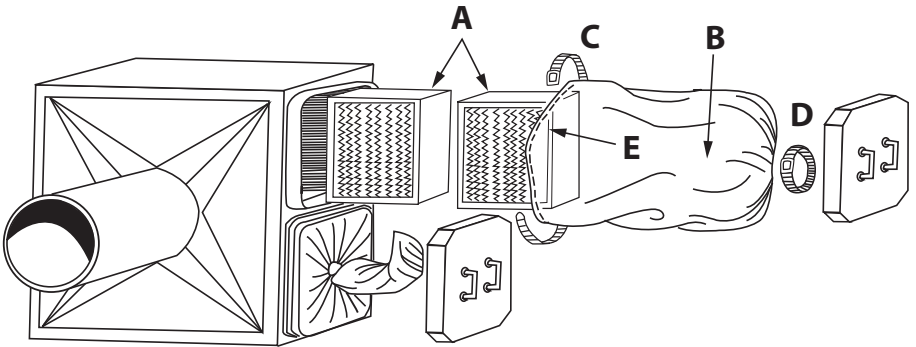

Figure 13. A bag-in-bag-out filter enclosure allows for the removal of the contaminated filter without worker exposure. A. filters, B. bags, C. safety straps, D. cinching straps, E. shock cord located in the mouth of the PVC bag restricts the bag around the second rib of the housing lip.



ACKNOWLEDGEMENTS

We gratefully acknowledge the Baker Company, Filtration Group, Inc., Flanders Filters and Forma Scientific, Inc. for use of some drawings and figures reproduced herein.

REFERENCES

1. Centers for Disease Control and Prevention; The National Institutes of Health. Biosafety in microbiological and biomedical laboratories. 5th ed. Washington, DC. 2007.
2. Kruse RH, Puckett WH, Richardson JH. Biological safety cabinetry. Clin Microbiol Rev. 1991;4:207-541.
3. First MW. Filters, high capacity filters and high efficiency filters: review and production. In-Place Filter Testing Workshop; 1971; Boston, Massachusetts. 1971.
4. The National Institutes of Health (NIH); Rockville Bio-Engineering Services, Dow Chemical USA. A Workshop for Certification of Biological Safety Cabinets. Bethesda: The Institute, Office of Biohazards and Environmental Control; 1974.
5. Richmond, JY. Safe practices and procedures for working with human specimens in biomedical research laboratories. J Clin Immunoassay. 1988;13:115-9.
6. Barbeito MS, Taylor LA. Containment of microbial aerosols in a microbiological safety cabinet. Appl Microbiol. 1968;16:1255-29.
7. Whitfield WJ. A new approach to clean room design. Final report. Albuquerque (NM): Sandia Corporation; 1962. Report No.: SC-4673 (RR).
8. NSF International (NSF); American National Standards Institute (ANSI). NSF/ANSI Standard 49-2004. Class II (laminar flow) biosafety cabinetry. Ann Arbor (MI); 2004.
9. Occupational Safety and Health Administration, Office of Occupational Medicine. Guidelines for cytotoxic (antineoplastic) drugs. Appendix A. Standard 01-23-001. 1986.

10. Jones RL Jr., Tepper B, Greenier TG, et al. Effects of Thimble Connections of Biological Safety Cabinets. Abstracts of 32nd Biological Safety Conference; 1989; New Orleans, LA: 1989.
11. National Institutes of Health (NIH). NIH guidelines for the laboratory use of chemical carcinogens. Washington, DC: U. S. Government Printing Office; 1981.
12. Class II. Type 1 safety cabinet specification the National Institute of Health-030112. The Institute; 1973, May.
13. Stuart DG, First MW, Jones RL Jr., et al. Comparison of chemical vapor handling by three types of class II biological safety cabinets. Particulate and Microbial Control. 1983;2:18-24.
14. Stuart D, Kiley M, Ghidoni D, et al. The class III biological safety cabinet. In: Richmond JY, editor. Anthology of biosafety vol. VII. biosafety level 3. Mundelein, IL: American Biological Safety Association; 2004.
15. American Conference of Government Industrial Hygienists (ACGIH). Threshold limit values for chemical substances and physical agents and biological exposure indices. Cincinnati, OH: ACGIH; 2006.
16. National Institutes of Health NIH, National Cancer Institute (NCI), Office of Research Safety and the Special Committee of Safety and Health Experts. Laboratory safety monograph: a supplement to the NIH guidelines for recombinant DNA research. Bethesda (MD): The Institute; 1979.
17. Barbeito M, West, D, editors. Laboratory ventilation for hazard control. Proceedings of a Cancer Research Safety Symposium; 1976 Oct 21-22; Frederick, MD: Litton Bionetics, Inc.; 1976.
18. National Cancer Institute Safety Standards for Research Involving Chemical Carcinogens. Bethesda: The National Institutes of Health (US), National Cancer Institute; 1975.

19. Anderson RE, Stein L, Moss ML, et al. Potential infectious hazards of bacteriological techniques. J Bacteriol. 1952;64:473-81.
20. Baker Company. Factors to consider before selecting a laminar flow biological safety cabinet. Sanford (ME): Baker Company; 1993.
21. Jones R, Drake J, Eagleson D. 1993. US hydrogen peroxide vapor to decontaminate biological cabinets. Acumen. 1993;1:1.
22. Jones R, Stuart D, Large S, et al. 1993. Cycle parameters for decontaminating a biological safety cabinet using H₂O₂ vapor. Acumen, 1993;1:2.
23. Jones R, Stuart D, PhD, Large S, et al. Decontamination of a HEPA filter using hydrogen peroxide vapor. Acumen. 1993;1:3.
24. Fox D, editor. Proceedings of the National Cancer Institute symposium on design of biomedical research facilities. Monograph series. Volume 4; 1979 Oct 18-19; Frederick, MD: Litton Bionetics, Inc.; 1979.
25. American Society of Heating, Refrigeration and Air Conditioning Engineers, Inc. (ASHRAE). Laboratories. In: ASHRAE Handbook, 1982 Applications. Atlanta (GA): ASHRAE; 1982.
26. US Department of Agriculture (USDA), Agricultural Research Services (ARS). ARS construction project design standard manual, 242.1. Beltsville (MD): USDA; 1991.
27. American Conference of Governmental Industrial Hygienists (ACGIH). Industrial ventilation, a manual of recommended practice. Cincinnati (OH): ACGIH; 1998.
28. Jones RL, Jr., Stuart DG, Eagleson D, et al. The effects of changing intake and supply air flow on biological safety performance. Appl Occup Environ Hyg. 1990;5:370.

29. Jones RL, Jr., Stuart DG, Eagleson, D, et al. Effects of ceiling height on determining calculated intake air velocities for biological safety cabinets. Appl Occup Environ Hyg. 1991;6:683.
30. Rake BW. Influence of cross drafts on the performance of a biological safety cabinet. Appl Env Microbiol. 1978;36:278-83.
31. Specifications for general purpose clean air biological safety cabinet. Bethesda: The National Institutes of Health (US), National Cancer Institute; 1973.
32. Airborne Particulate Cleanliness Classes in Clean rooms and Clean Zones, Federal Standard No. 209E. (1992).
33. Clean Room and Work Station Requirements, Controlled Environment, Federal Standard No. 209B. (1973).